

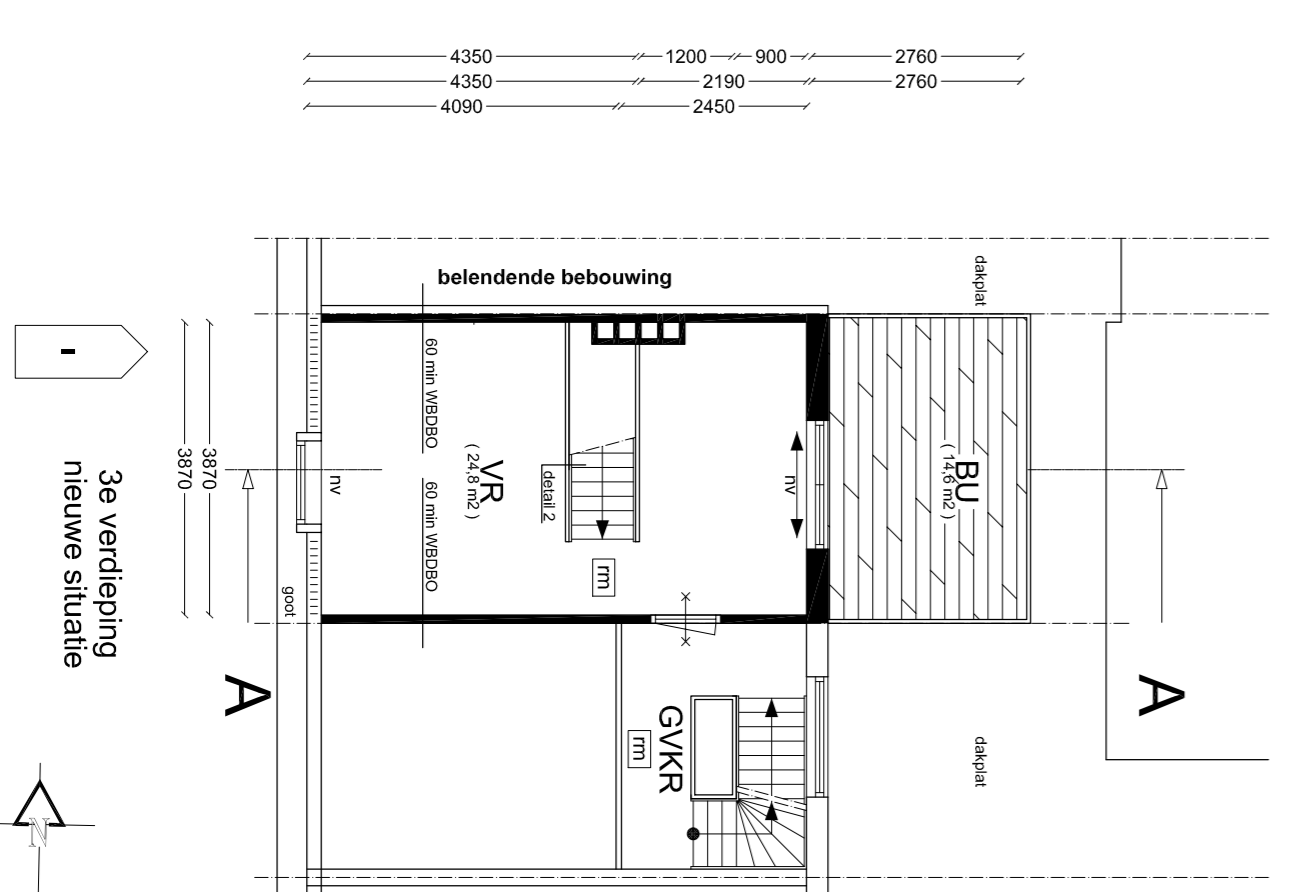

SITUATIE 1:1000  
Sectie C, nr 8121

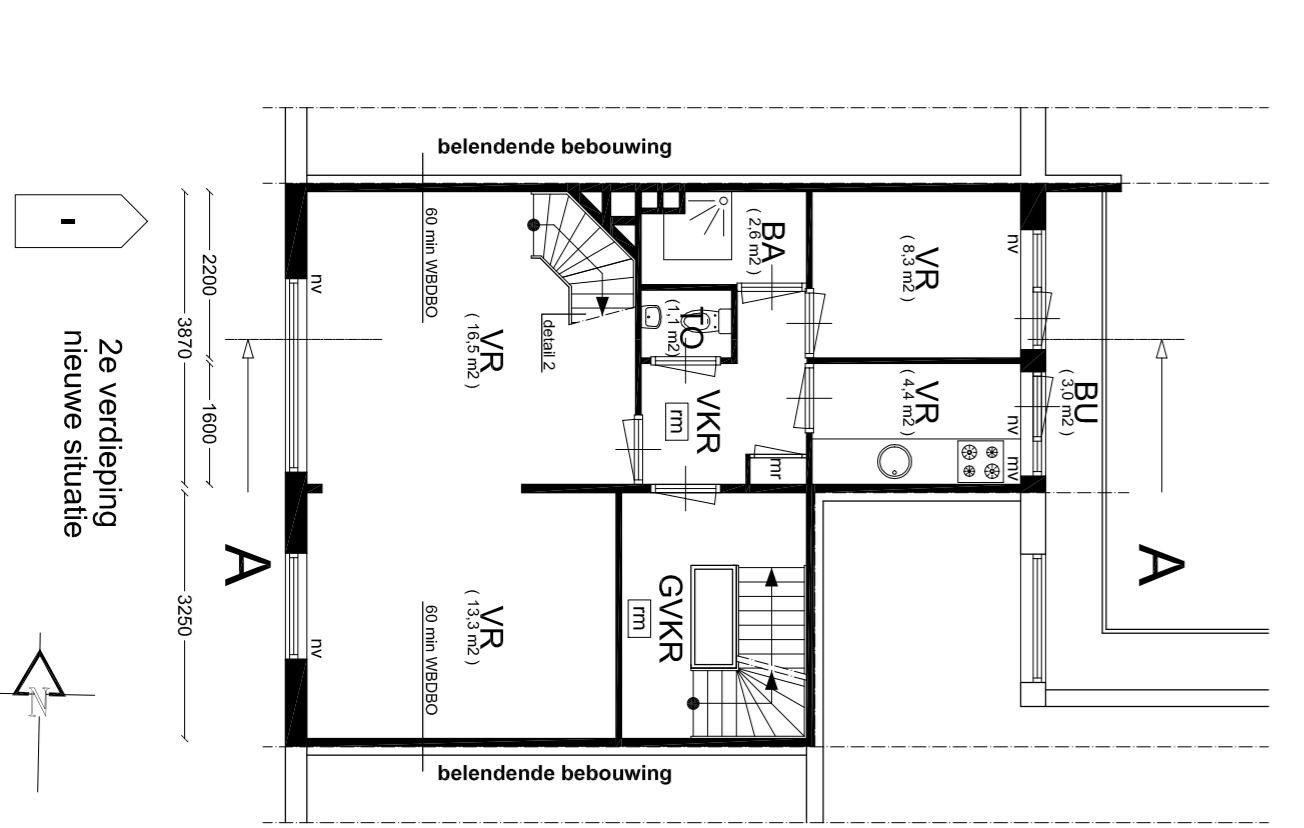
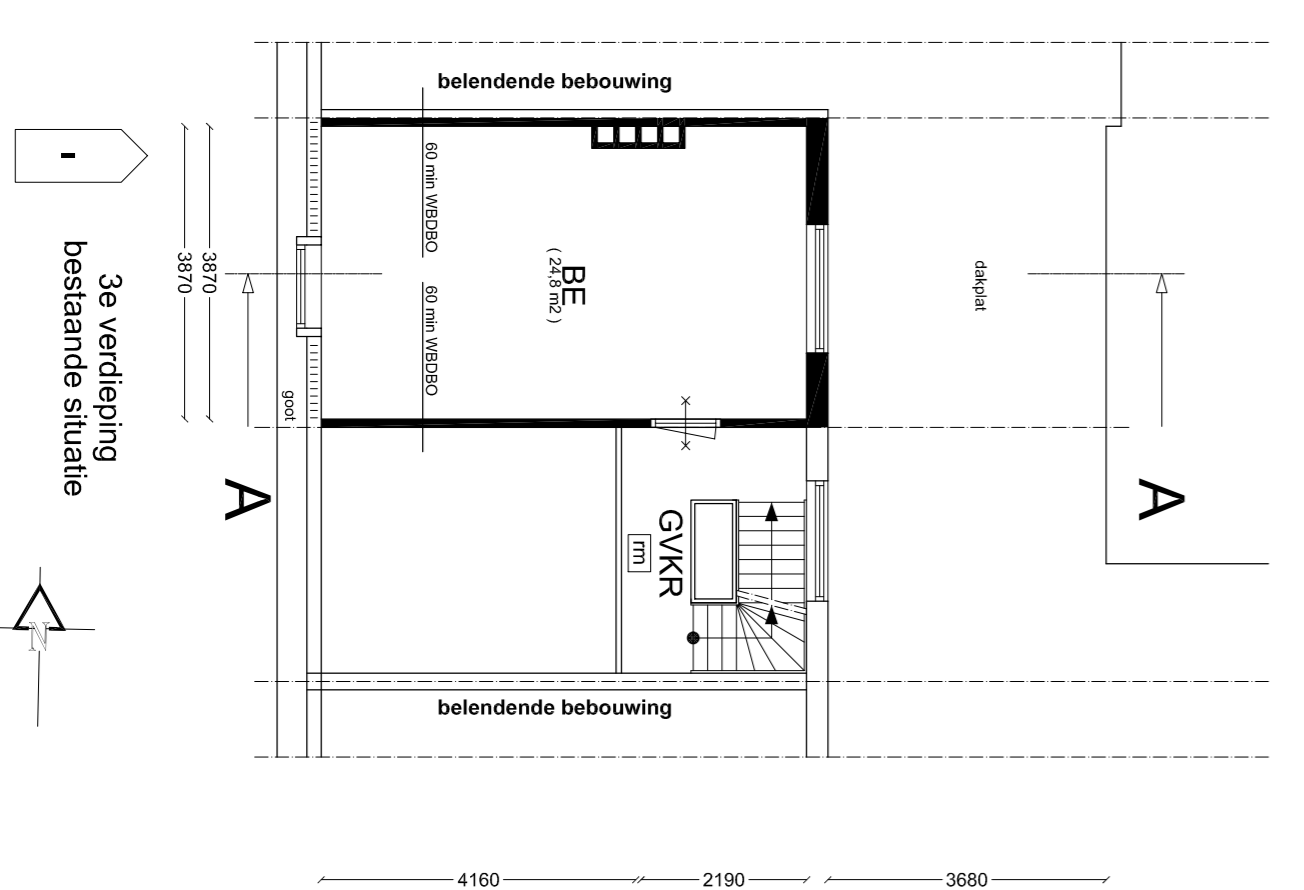
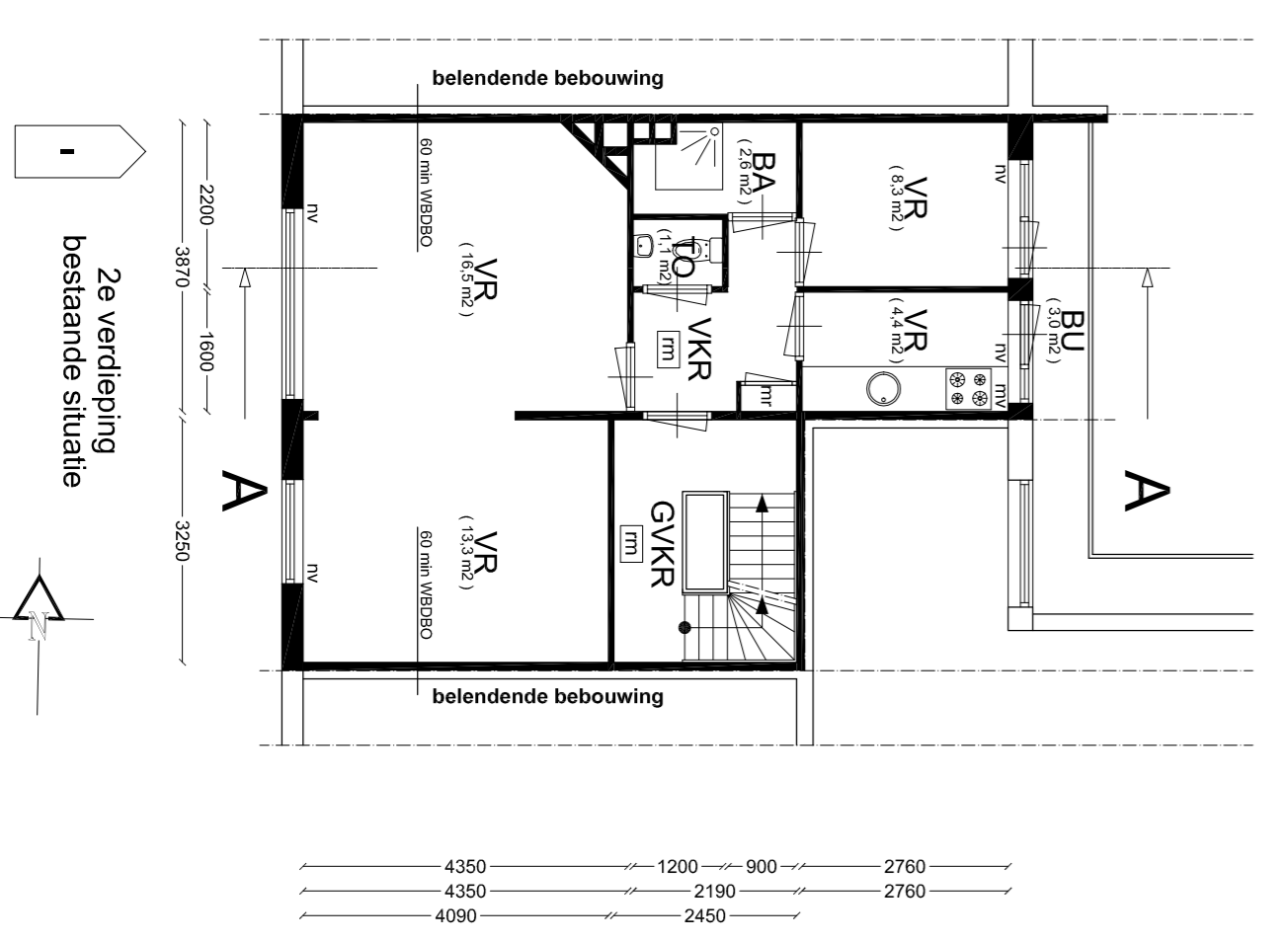
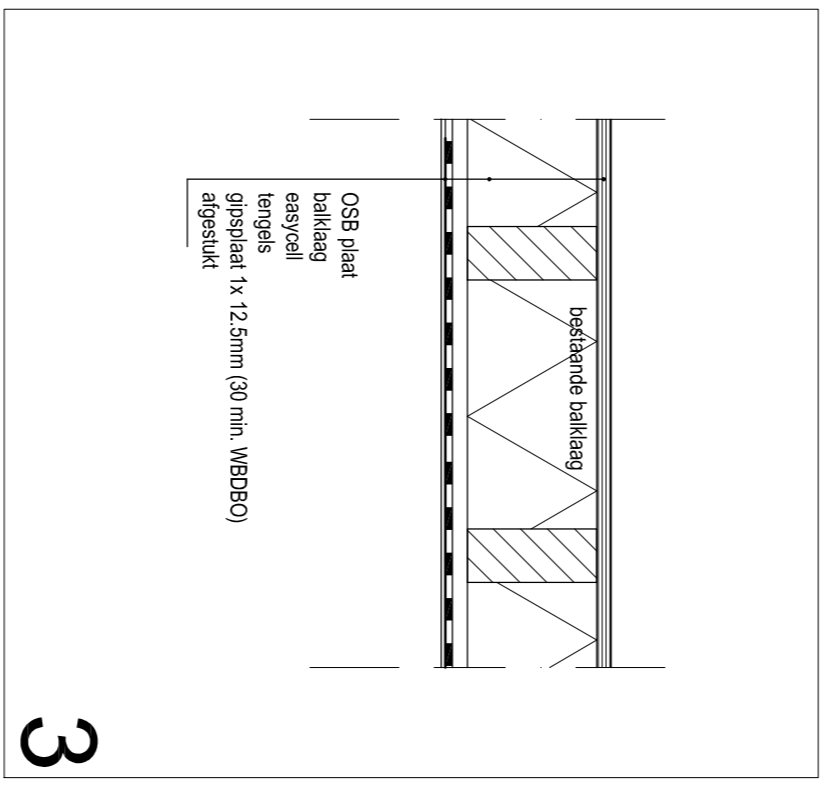
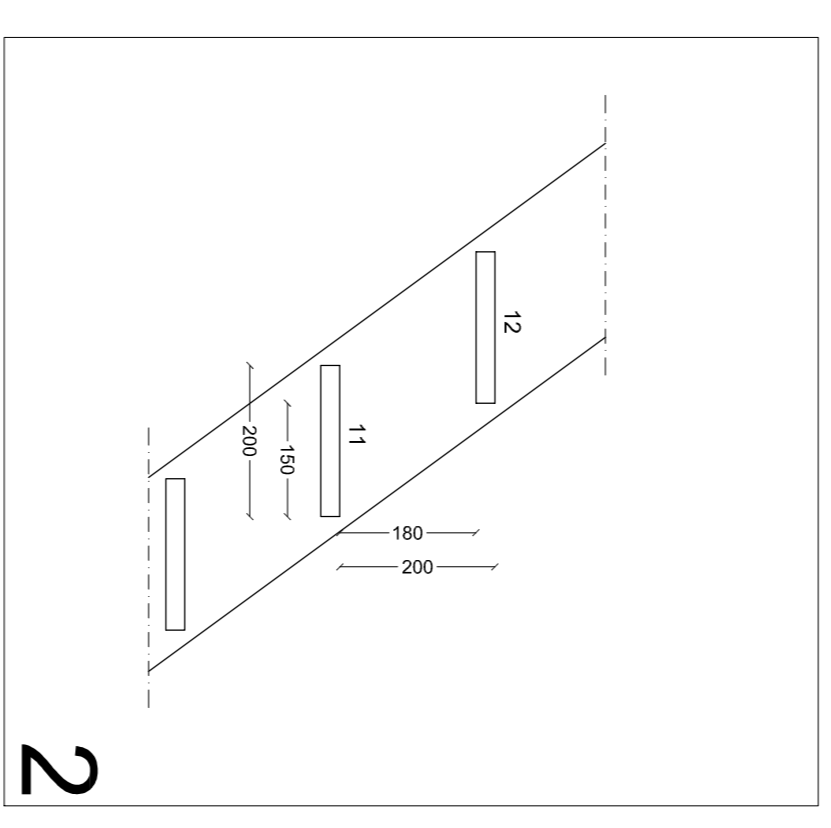
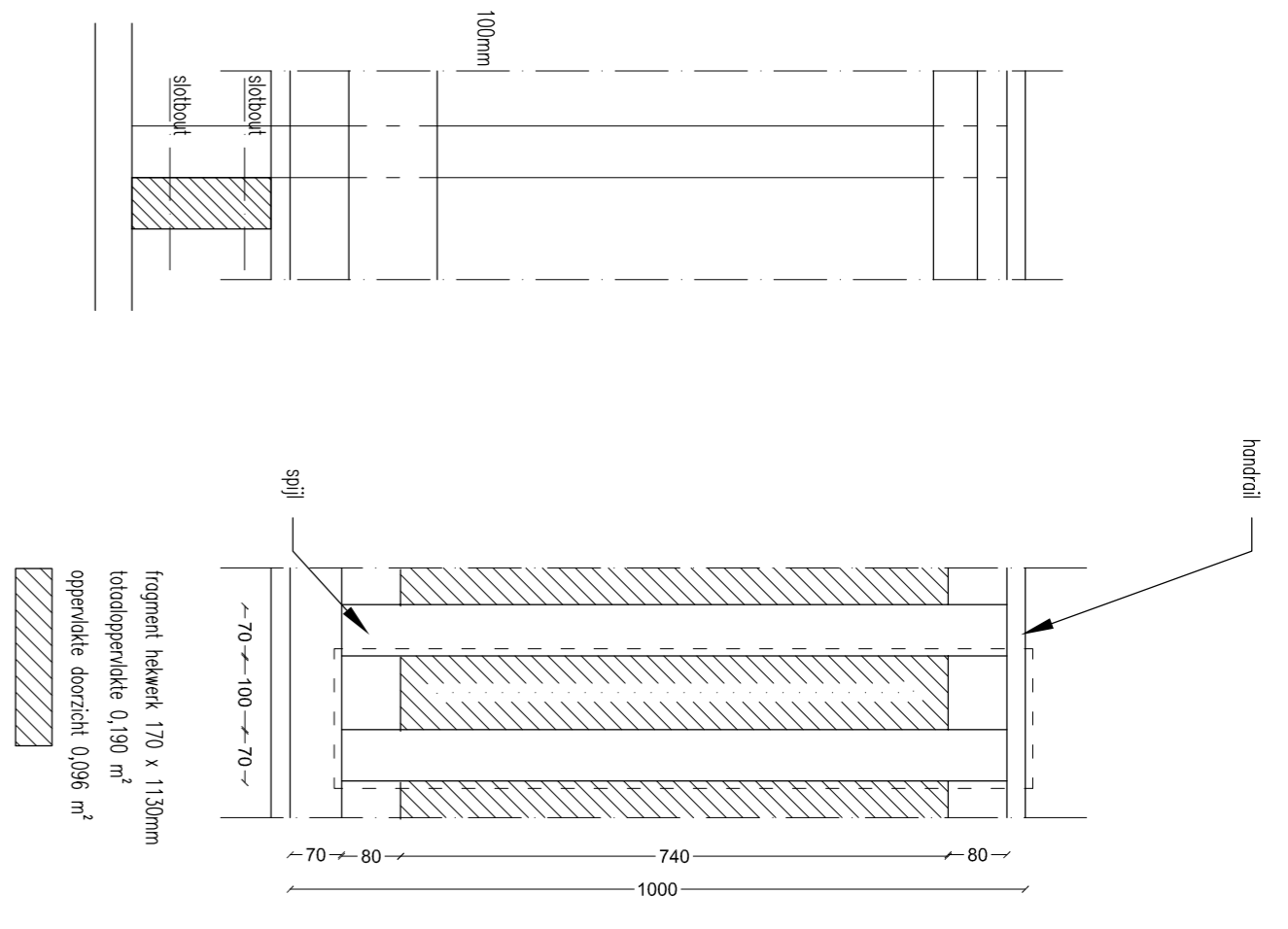
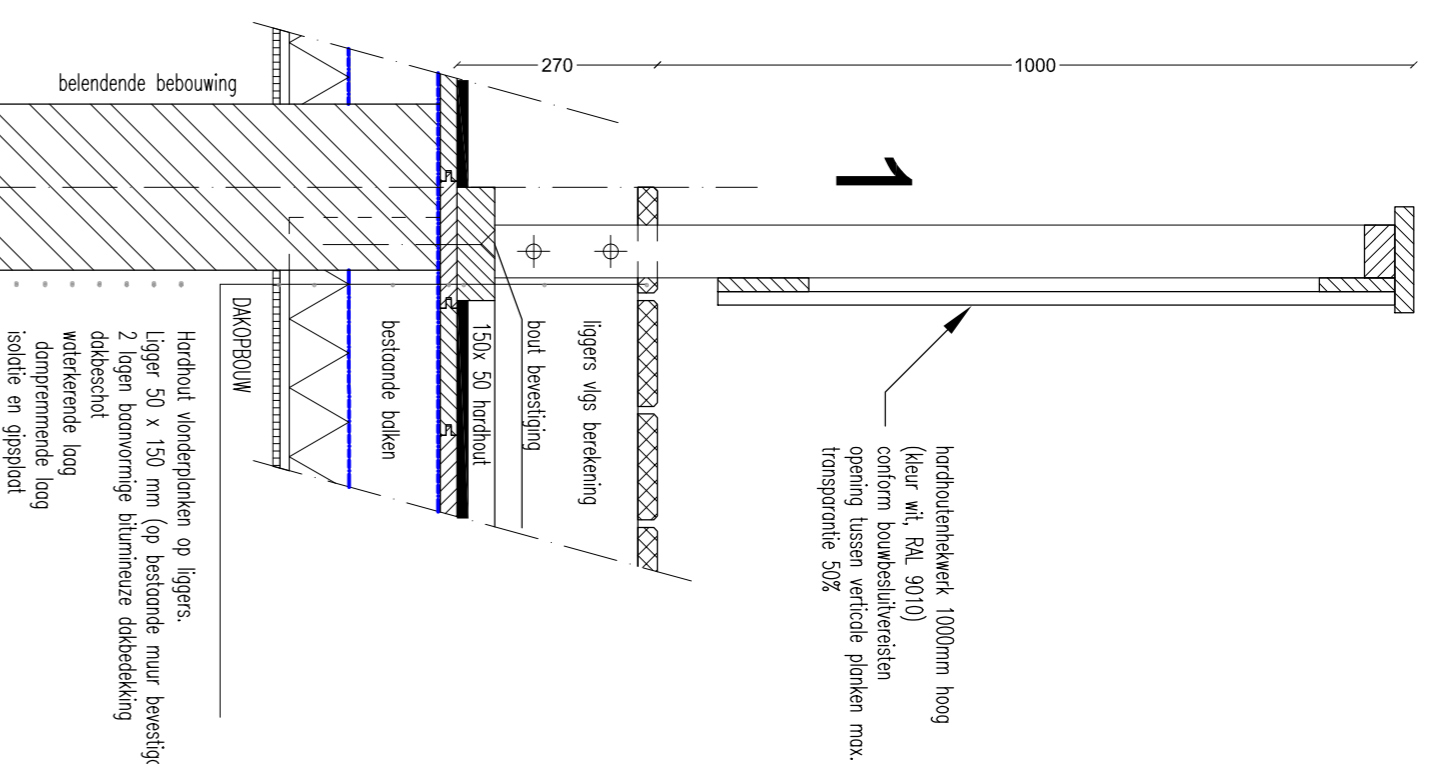
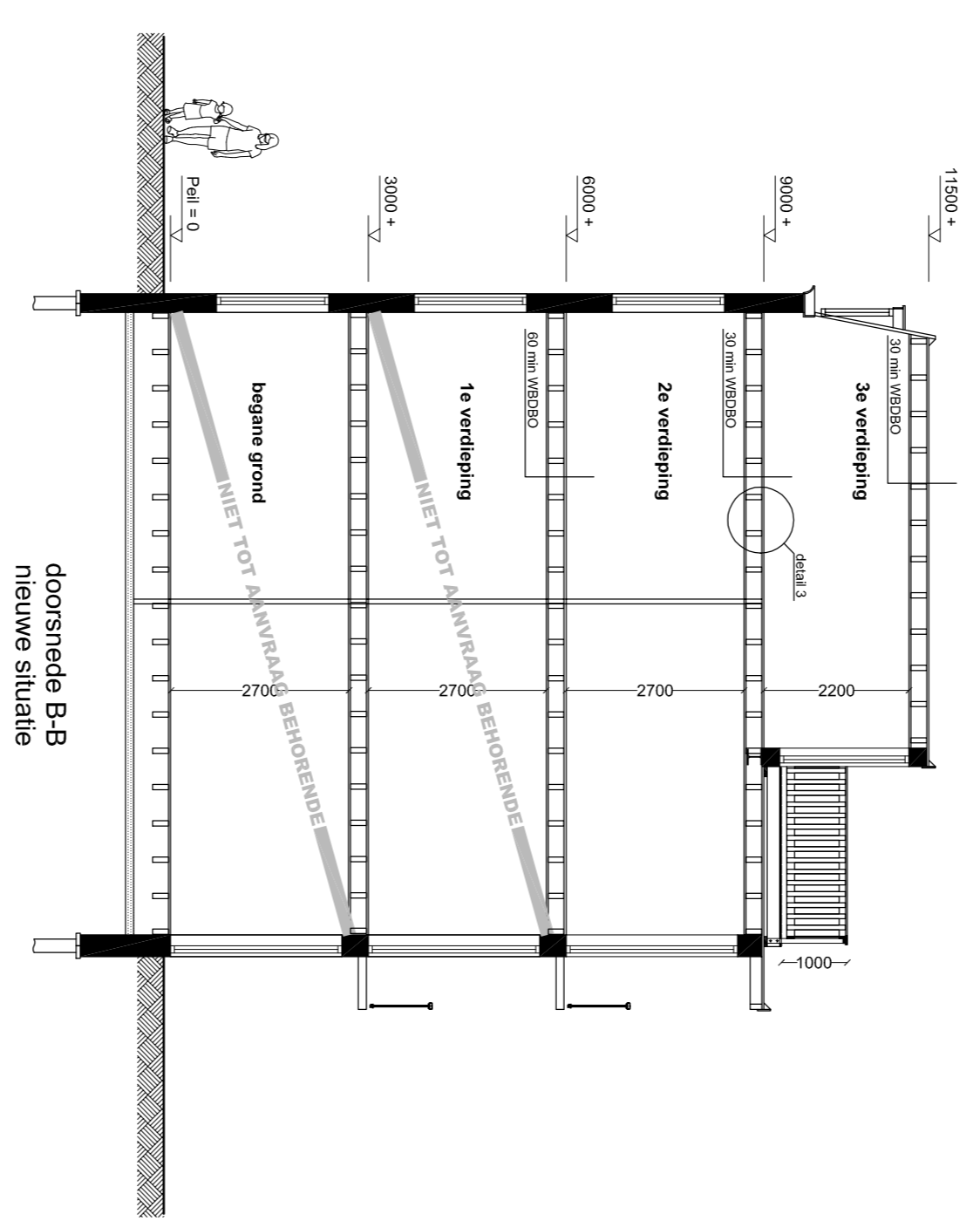
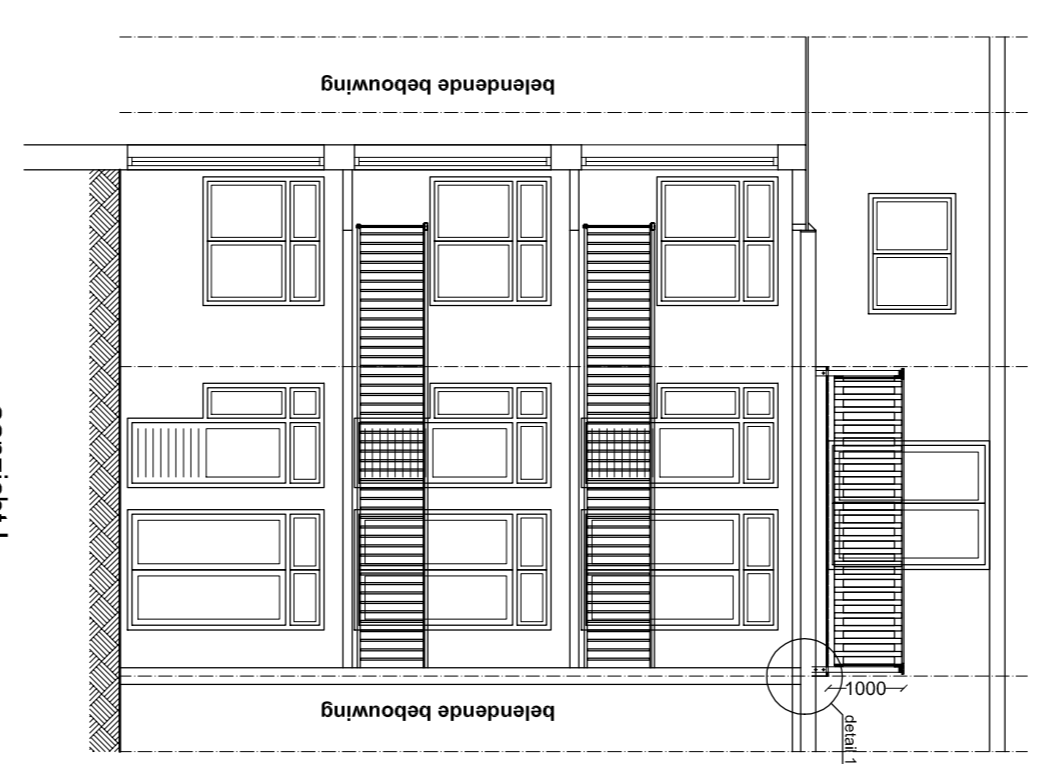
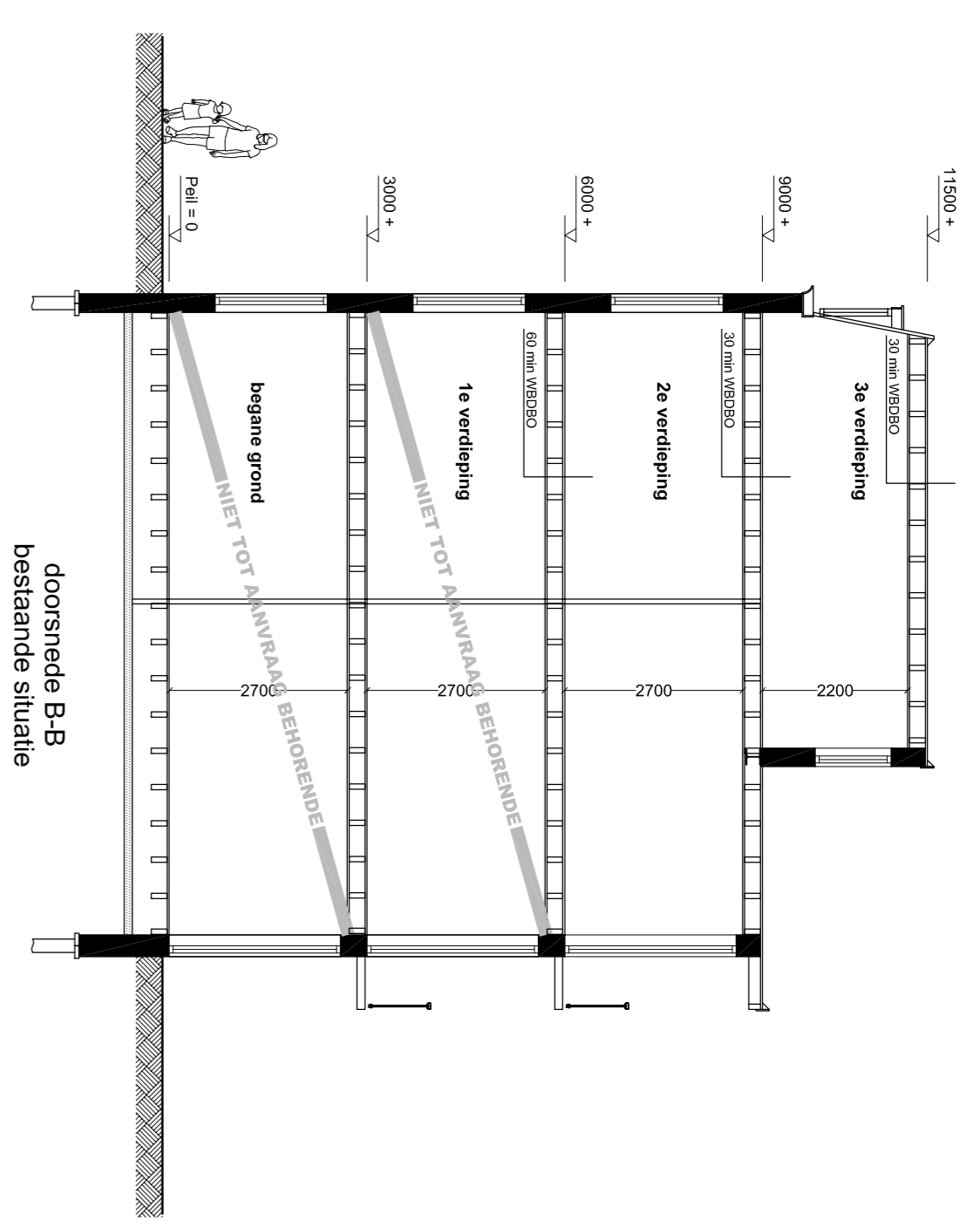
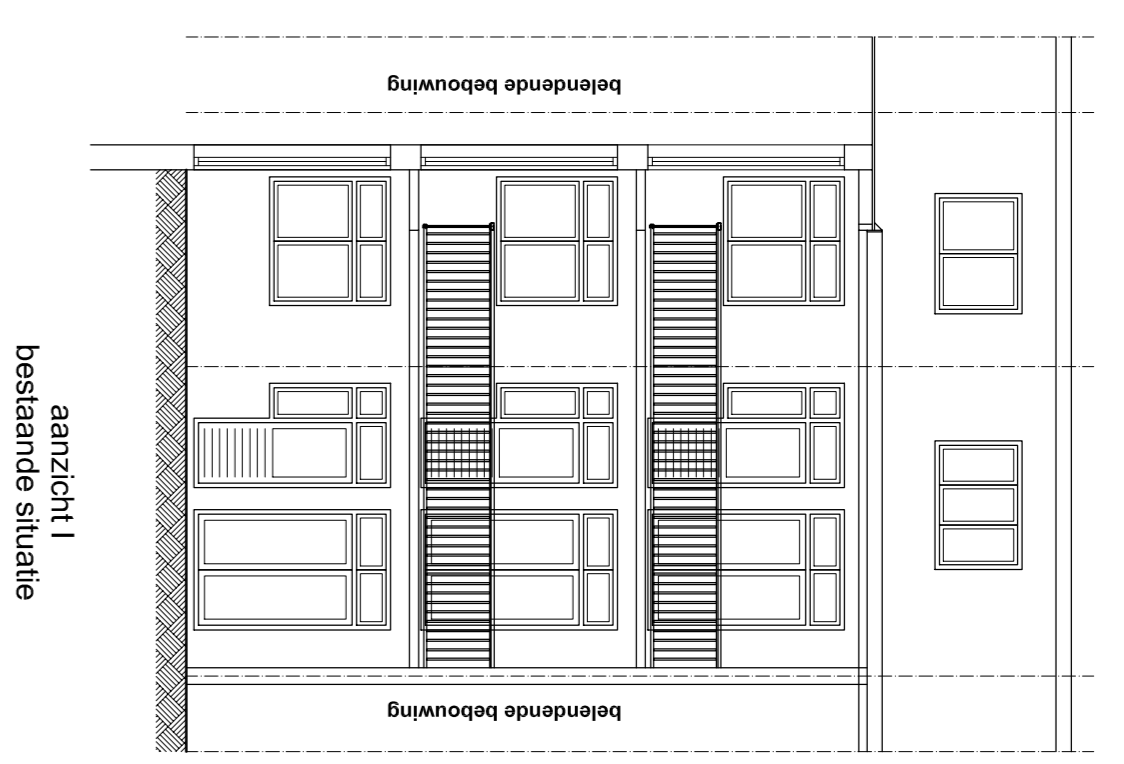

**Legend**

VR	==	verhuurruimte
TO	==	toiletruimte
BA	==	badruimte
BE	==	bergruimte
VKR	==	verkeersruimte
GVKR	==	gemeenschappelijke verkeersruimte
BU	==	buikruimte
BR	==	bergruimte
M	==	meubelruimte
K	==	keuken
hwv	==	warm watervoorziening
nrv	==	natuurlijke ventilatie
mv	==	mechanische ventilatie
30	==	30 minuten brandbestendig
60	==	60 minuten brandbestendig
X	==	afgesloten

**Van Toepassing zijnde normen**

elektrische installaties	conform NEN 1010
centrale verwarming	conform NEN 3028
ventilatie	conform NEN 1087
trappen	conform NEN 3009
licht- en conditieschuld	conform NEN 5077
toegankelijkheid	conform NEN 5077
brandveiligheid	conform NEN 6098

**opmerkingen**

gevelschild blijft ongewijzigd  
mankering in het werk te corrigeren

**BOUWKONING TECHNIEURBLANK**

adres: Polder Looswijk, Talsmaal 13c  
plaats: 1073 KH Amsterdam  
telefoon: 06-4724 30 70  
website: www.technieurbank.nl  
e-mail: info@technieurbank.nl

**locatie** AMSTERDAM  
**datum** 26-07-2017  
**1e wijziging** 29-09-2017  
**2e wijziging** --  
**3e wijziging** --  
**getekend** FV  
**getekend** FV  
**schakel** 1:100  
**format** A1  
**teken** MM  
**blad** 1/1

**T-01**  
Behoort bij beschikking met  
Olo-nummer 3134239  
d.d. 27 oktober 2017

**project** VAN GENTSTRAAT 28  
**titel** VERGUNNINGSAANVRAAG